

1 2 3 4 5 6 7 8

DO NOT SCALE DRAWING IF IN DOUBT - ASK 3rd ANGLE PROJECTION

DRAWING NUMBER		
<b>PEC-100-150-CD</b>		
ISSUE	DESCRIPTION	DATE
A	RELEASED FOR PRODUCTION	05/01/05

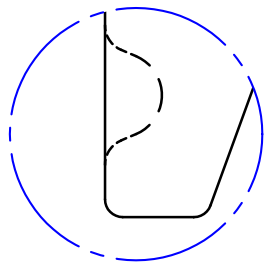
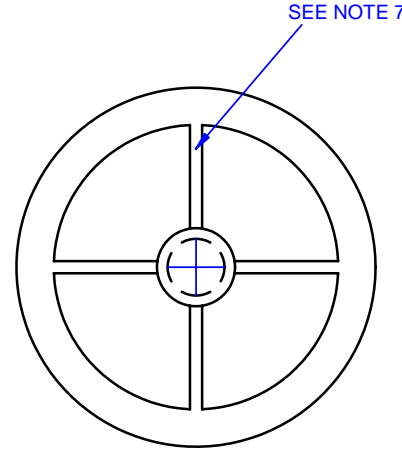
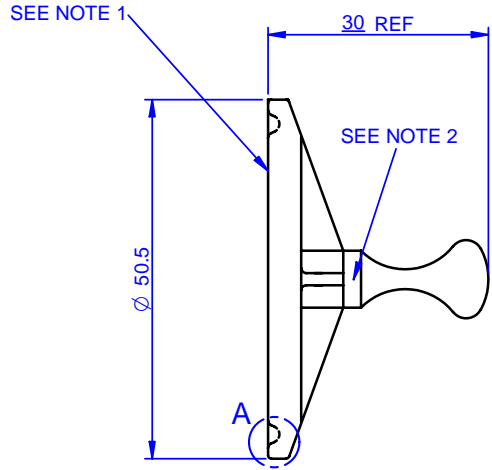

**DETAIL A**  
TO CONFORM TO RELEVANT  
ISO, BS & DIN STANDARDS

- NOTES:**
1. THIS FACE TO BE FLAT TO 0.15 mm. MAXIMUM EJECTOR WITNESS PERMISSABLE 0.07mm.
  2. BATCH CODE TO BE MOULDED ON PART IN THIS AREA.
  3. NO FLASH OR IMPERFECTION PERMISSABLE ON FRONT EDGE OF MOULDING.
  4. NO CONTAMINATION ALLOWED.
  5. MAXIMUM SPLIT LINE FLASH 0.2 mm.
  6. PART TO BE MANUFACTURED IN CLEANROOM ENVIROMENT.
  7. INJECTION GATE MARK TO BE TRIMMED FLUSH.

<p>© COPYRIGHT</p> <p>This drawing and its associated design is the property of Bio-Pure Technology Ltd &amp; may not be copied or used for any purpose other than that for which it is supplied, without the express written authority of Bio-Pure Technology Ltd</p>	<p>DIMENSIONS IN MILLIMETERS</p> <p>TOLERANCES UNLESS STATED</p> <p>0 DEC PLACE +/- 0.5</p> <p>1 DEC PLACE +/- 0.25</p> <p>2 DEC PLACES +/- 0.10</p> <p>ANGULAR +/- 0.5 DEG</p>	<p>MATERIAL AND SPECIFICATION</p> <p>PP Natural</p> <p>Borealis HD810MO</p>	DRAWN BY	DATE	FINISH	<p>Bio-Pure Technology Ltd.</p> <p>17 South Street, Havant, Hants PO91BU ENGLAND</p> <p>Tel. +44 (0) 2392 499000 Fax. +44 (0) 2392 499001</p> <p>Email. sales@biopuretech.com</p> <p>Web. www.biopuretech.com</p>	TITLE
			CHECKED BY	APPROVED BY	SCALE		<p>BIO-BARB</p> <p>LARGE BLANK</p>
			MJF	10/11/04	CLEAN		
			PRW	RW	1:1		PART No: PEC-100-150