

DO NOT SCALE DRAWING

IF IN DOUBT - ASK

3rd ANGLE PROJECTION

DRAWING NUMBER

PP0625BY-CD

ISSUE	DESCRIPTION	DATE
1	INITIAL DRAWING	26/04/05

PATENT PENDING GB 0509362.0
 PATENT PENDING US 11/053657
 PATENT PENDING EEC 05075275.7

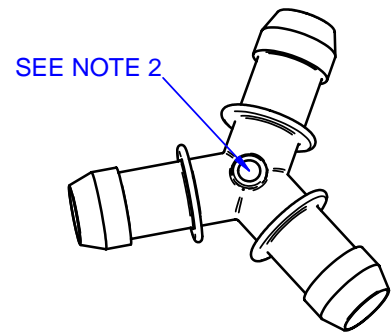
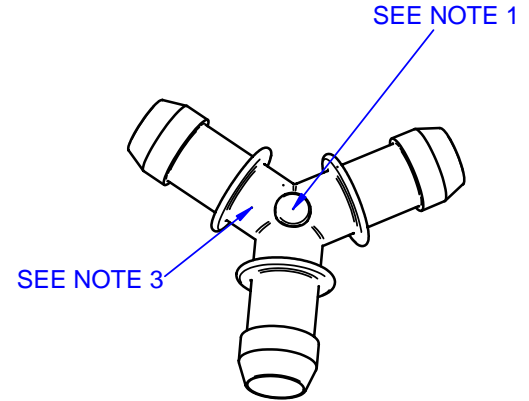
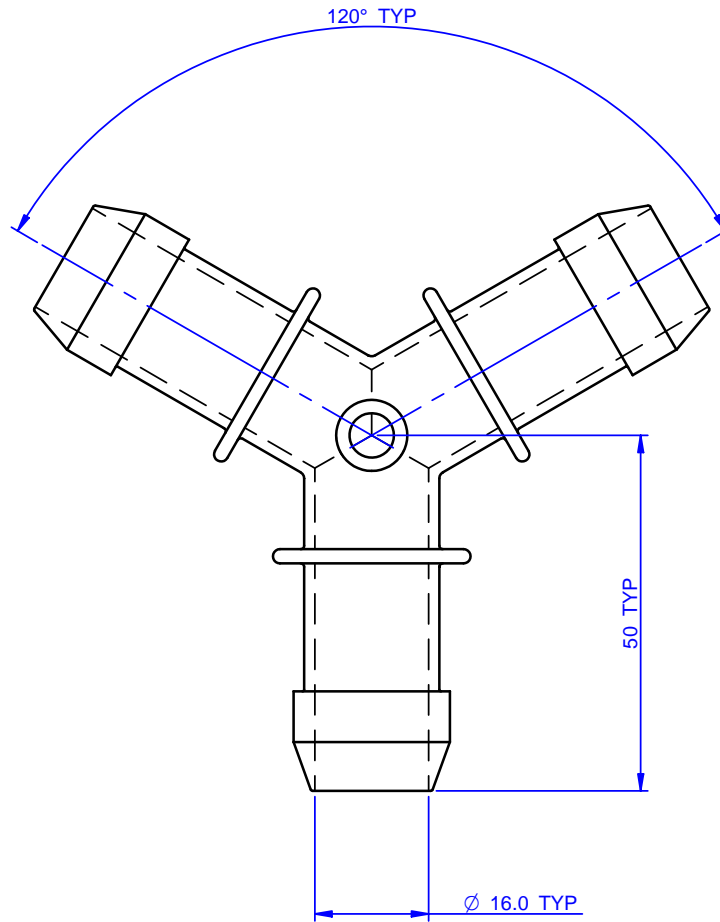
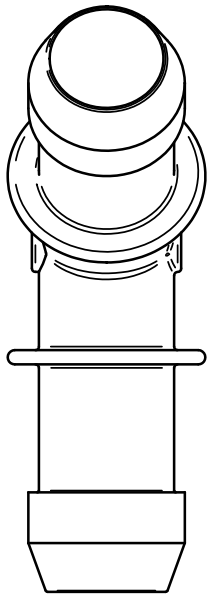

NOTES:

- BATCH CODE TO BE MOULDED ON PART IN THIS AREA.
- INJECTION FEED MARK TO BE FLUSH.
- COMPONENT SIZE IDENTIFICATION TO MOULDED IN THIS POSITION.
- NO FLASH OR IMPERFECTIONS PERMISSABLE ON FRONT EDGE OF SPOUTS.
- NO FLASH PERMISSABLE ON INTERNAL CORE INTERSECTION.
- NO CONTAMINATION ALLOWED.
- PART TO BE MANUFACTURED IN CLEANROOM ENVIROMENT.

© COPYRIGHT

This drawing and its associated design is the property of Bio-Pure Technology Ltd & may not be copied or used for any purpose other than that for which it is supplied, without the express written authority of Bio-Pure Technology Ltd

DIMENSIONS IN MILLIMETERS

TOLERANCES UNLESS STATED
 0 DEC PLACE +/- 0.5
 1 DEC PLACE +/- 0.25
 2 DEC PLACES +/- 0.10
 ANGULAR +/- 0.5 DEG

MATERIAL AND SPECIFICATION

PP Natural
 Borealis HD810MO

DRAWN BY

MJF

CHECKED BY

PR

DATE

26/04/05

APPROVED BY

RM

FINISH

CLEAN

SCALE

1:1

Bio-Pure Technology Ltd.

17 South Street, Havant, Hants PO91BU ENGLAND
 Tel. +44 (0) 2392 499000 Fax. +44 (0) 2392 499001
 Email. sales@biopuretech.com
 Web. www.biopuretech.com

TITLE

5/8" BIO Y CONNECTOR

PART No:

PP0625BY